

amt  
**postpro**<sup>®</sup>



**postpro**<sup>®</sup> DP  
ERGONOMIC  
DEPOWDERING  
SYSTEM

V3 / DECEMBER 2020

\*SPECIFICATIONS SUBJECT TO CHANGE

## CERTIFICATIONS

The POSTPRODP is CE certified . POSTPRODP is ISO 9001-2015 certified. The POSTPRODP is designed to be used in processes where the consumable media and dust are combustible. There are safety components in the machine to reduce the risk of fire or explosion. Atex class is Class II 3/-D T125°C.

## DIMENSIONS

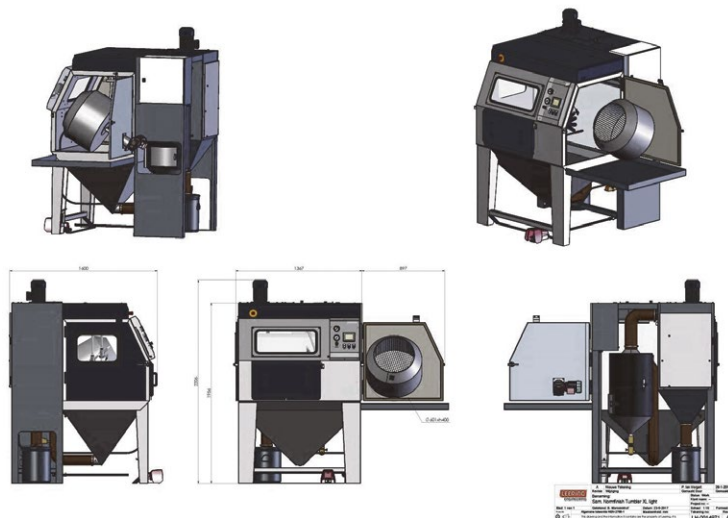

## TECHNICAL SPECIFICATIONS

Description	EU
<b>External dimensions (w x d x h):</b>	1.626 x 1.600 x 2.206 mm
<b>Effective blast room (l x w x h):</b>	1.320 x 940 x 1060 mm
<b>Working height:</b>	725 mm
<b>Door openings (w x h) (2 pieces)</b>	835 x 825 mm
<b>View window (w x h):</b>	656 x 266 mm
<b>Maximum load cabinet:</b>	350 kg
<b>Basket with lining:</b>	
• Dimensions	Ø 600 x 400 mm
• Approx. volume (depends on size and form of products)	30 liter
• Maximum load	15 kg
<b>Blast guns basket (2 pieces):</b>	Hardened blast guns with boron carbide nozzles (Ø 8 mm)
<b>Filter cartridges (polyester, M-class):</b>	2 filter cartridges of 4 m <sup>2</sup> each
<b>Capacity ventilator:</b>	800 m <sup>3</sup> /h (1,1 kW)
<b>Dust emission:</b>	< 1,8 mg/Nm <sup>3</sup>
<b>Atex classification:</b>	Class II 3/-D T125°C
<b>Lighting:</b>	LED light 50 Watt
<b>Electrical connection:</b>	3 x 400V, 50hz, earth and zero, 16A
<b>Total power consumption:</b>	1,3 kW
<b>Pneumatic connection/pressure</b>	G 1/2" air supply hose, 6 bar
<b>Cabin weight (complete):</b>	570 kg
<b>Min. Pneumatic flow rate</b>	Minimum 2.02m <sup>3</sup> /min

\*Specifications are subject to change

## SYSTEM DESCRIPTION

Construction: All components are assembled into one compact unit. Cabinet has an ergonomic working height.

### MANUAL BLAST PROCESS:

Manual blasting is possible by removing the protective cover which closes the gloves off. Because of personal safety after removal of this cover there is no automatic process possible.

### VIEW WINDOW:

The big view window consists of a safety glass and an extra splash glass which can be easily changed at the front by means of a quick fixation.

### DOORS:

Both doors are designed with a sandwich construction for obtaining a sturdy construction and perfect sealing. With an open door, no blasting is possible due to the installed safety switches.

### IONISATION UNIT:

The ionisation unit is used to create ionised air which reduces static electricity and so the attachment of dust to the parts. The used unit is ATEX certified.

### CYCLONE:

The cyclone ensures perfect blast media cleaning and a constant operating mixture (= constant blasting result). An additional coarse screen also has been installed to prevent clogging of the mixing chamber.

### EXTRACTION:

A ventilator with a high extraction rate has been installed for a good view in the blast room. Cleaning of the filters is fully automatic. Cleaning pressure is adjustable via an additional pressure regulator.

### DUST BIN:

The dust from the filter unit is collected in a sealed dust bin.

### MIXING CHAMBER:

The mixing chamber is placed under the cyclone. This can be easily adjusted so that a perfect air / abrasive mix is obtained for all common abrasives. The abrasive can easily be changed via a plug placed on the underside of the mixing chamber.

### NOISE LEVEL:

Low noise level due to the installed silencer (<79dB(A) at 3 bar).



## SYSTEM OPERATION

- Product is placed in the basket which is mounted to the right access door.
- The blasting time, blow off time, and rotation speed of the basket are set on the touch panel.
- The blast pressure is set by a pressure regulator.
- After closing the doors the process can begin.

Blast media, dust and contamination are sucked out of the blast chamber to the cyclone via the suction hose. The dust and contamination is removed from the blasting media in the cyclone. Dust is removed in the filter so that the exhausted air complies with regulations. Dust collection is in a sealed dust bin.

The filter is cleaned automatically via reverse air pulses.

Cleaning of the products is with ionised air to reduce the static electricity and also reduce the attachment of dust to the parts.

## TUMBLER AND ADD-ON'S

### SPECIFIC CHARACTERISTICS:

- Basket:** The basket is equipped with mixers and attached to the right access door.
- Drive:** Driven by motor-reducer, with control for adjustable tumbler speed. Adjustable between 7 and 14 rpm. Placed outside the cabinet.
- Timer:** Timer to set blast period and cleaning time to remove dust and media by the touch panel.
- Nozzle holder:** Adjustable nozzle holder with quick-change system for removing the blast gun.
- Window:** Additional window in the door to optical control the process.

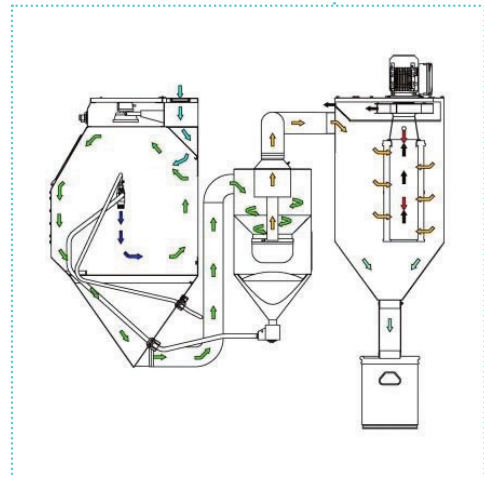

## BLAST MEDIA

The cabinets are suitable for all common abrasives such as corundum, glass beads, ceramics, nut shells, plastic and fine grain sizes of stainless steel and steel.

To determine which abrasive is most suitable for your process, Leering can perform tests and provide advice free of charge. Delivery of all types of abrasive is normally out of stock.

## WARRANTY

The warranty period is 12 months after delivery and applies to material and construction defects. Parts subject to normal wear and tear are excluded from this.

In the event of a warranty case, the parts will be sent free of charge.

During the warranty period, only blast media and parts from AMT may be used without permission.

The compressed air must be clean and dry and must comply with ISO8573.1 class 4.

Products to be blasted must also be dry and free of grease.





## CONTACT INFORMATION

For Further information please contact Additive Manufacturing Technologies:

[support@amtechnologies.com](mailto:support@amtechnologies.com)

EU: +44 114 3122 3344

US: +1 512 352 9393

